

# WAS4735Q

## 4:1 High speed (-3dB bandwidth 1.2GHz) Switch

### Descriptions

The WAS4735Q is a bi-directional, low power, high-speed 4:1 switch that operates from a single +2.3V to +5.5V power supply.

The WAS4735Q is designed for switching of high-speed (-3dB bandwidth 1.2GHz) signals in handset and consumer applications, such as cell phones, digital cameras, and notebooks with hubs or controllers with limited USB I/Os.

The WAS4735Q has low bit-to-bit skew and high channel-to-channel noise isolation, and is compatible with various standards, such as high-speed USB 2.0 (480Mbps), MHL video 720p/60fps and 1080i/30fps. Each switch is bi-directional and offers little attenuation of the high-speed signals at the outputs. Its bandwidth is quite marginal to pass high-speed differential signals (2.4Gbps) with good signal integrity.

The WAS4735Q is featured with special circuitry on the D+/D-, which allows the device to withstand a VBUS short to D+ or D- when the USB devices are either powered off or on.

The WAS4735Q is available in QFN1826-16L package. Standard products are Pb-Free and halogen-Free.

### Applications

- Cell phones
- MID
- Router
- Other electronics equipments

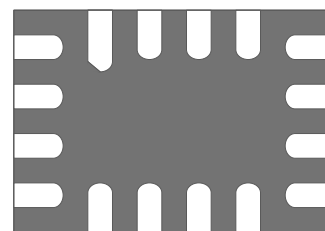

**QFN1826-16L**

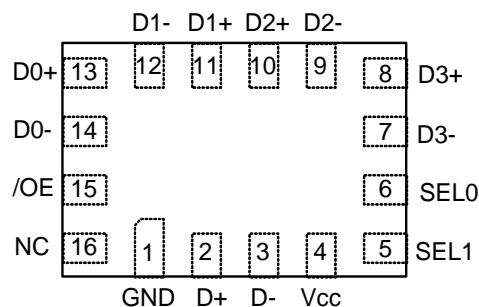

**Pin configuration (Top view)**



**Marking**

DF = Device code

\* = Month (A~Z)

### Order information

Device	Package	Shipping
WAS4735Q-16/TR	QFN1826-16L	3000/Reel&Tape

### Features

- Supply voltage : 2.3 ~ 5.5V
- -3dB Bandwidth : 1.2GHz @ C<sub>L</sub>=0pF
- Off isolation : -50dB @ 250MHz
- Crosstalk : -30dB @ 250MHz
- Low quiescent current : 60uA typical

**WAS4735Q**

**Pin descriptions**

Pin Number	Symbol	Descriptions
1	GND	Ground
2	D+	D+ Common Port (HS or FS USB)
3	D-	D- Common Port (HS or FS USB)
4	Vcc	Power Supply
5	SEL1	Path Selection Control Input (See Table Below)
6	SEL0	Path Selection Control Input (See Table Below)
7	D3-	D- From Fourth Source Path (HS or FS USB)
8	D3+	D+ From Fourth Source Path (HS or FS USB)
9	D2-	D- From Third Source Path (HS or FS USB)
10	D2+	D+ From Third Source Path (HS or FS USB)
11	D1+	D+ From Second Source Path (HS or FS USB)
12	D1-	D- From Second Source Path (HS or FS USB)
13	D0+	D+ From First Source Path (HS or FS USB)
14	D0-	D- From First Source Path (HS or FS USB)
15	/OE	Enable Control Input (See Table Below)
16	NC	No Connect

**Function descriptions**

/OE	SEL1	SEL0	Function
1	X	X	D+,D- Switch Paths Open
0	0	0	D+ = D0+, D- = D0-
0	0	1	D+ = D1+, D- = D1-
0	1	0	D+ = D2+, D- = D2-
0	1	1	D+ = D3+, D- = D3-

**Logic symbol and typical applications**

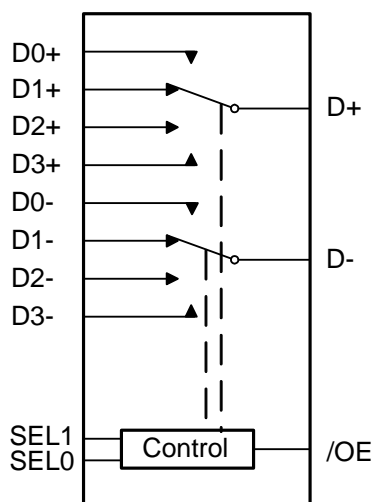

Logic Symbol

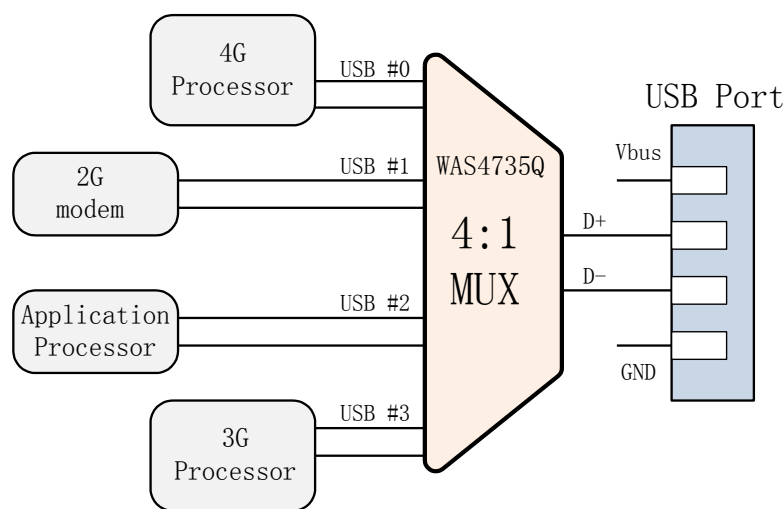

Typical Applications (Mobile Phone Example)

**Absolute maximum ratings**

Parameter	Symbol	Value	Unit
Supply voltage range	VCC	-0.5 ~ 6.5	V
Data input/output voltage range	V <sub>DATA</sub>	-0.5 ~ 6.5	V
Select input voltage range	V <sub>SEL</sub>	-0.5 ~ 6.5	V
Continues output current	I <sub>OUT</sub>	±50	mA
Junction temperature range	T <sub>J</sub>	150	°C
Lead temperature range	T <sub>L</sub>	260	°C
Storage temperature range	T <sub>STG</sub>	-65 ~ 150	°C
Thermal resistance	R <sub>θJA</sub>	250	°C/W
ESD protection (HBM)	I/O to VCC, I/O to GND	±6000	V
	I/O to I/O	±4000	V

**Recommend operating ratings**

Parameter	Symbol	Value	Unit
Supply voltage range	VCC	2.3 ~ 5.5	V
Data input/output voltage range	V <sub>DATA</sub>	0.0 ~ VCC	V
Select input voltage range	V <sub>SEL</sub>	0.0 ~ VCC	V
Enable control input voltage range	V <sub>OE</sub>	0.0 ~ VCC	V
Operating temperature range	T <sub>A</sub>	-40 ~ 85	°C

**Electronics Characteristics (Ta=25°C, VCC=4.5V, unless otherwise noted)**

Parameter	Symbol	Conditions	Min.	Typ.	Max.	Unit
Select and OE logic high level	V <sub>IH</sub>	VCC=3.0~4.5	1.7			V
		VCC=2.3~3.0	1.4			V
Select and OE logic low level	V <sub>IL</sub>	VCC=3.0~4.5			0.6	V
		VCC=2.3~3.0			0.4	V
Supply quiescent current	I <sub>CC</sub>	I <sub>OUT</sub> =0, V <sub>SEL</sub> >1.5V or V <sub>SEL</sub> <0.7V		60	80	uA
Select input leakage current	I <sub>SEL</sub>	V <sub>SEL</sub> =VCC			±1.0	uA
Off state switch leakage current	I <sub>OFF</sub>				±1.0	uA
On state switch leakage current	I <sub>ON</sub>				±1.0	uA
On-Resistance	R <sub>ON</sub>	VCC=3.0V, V <sub>DATA</sub> =0~0.4V, I <sub>OUT</sub> =8mA,		5.0	7.5	Ω
On-Resistance match	Δ R <sub>ON</sub>	VCC=3.0V, V <sub>DATA</sub> =0~0.4V, I <sub>OUT</sub> =8mA,		0.15	0.20	Ω
On-Resistance flatness	R <sub>FLAT(ON)</sub>	VCC=3.0V, V <sub>DATA</sub> =0~1.0V, I <sub>OUT</sub> =8mA,		1.8	2.2	Ω
Propagation delay time	T <sub>PLH</sub> / T <sub>PHL</sub>	C <sub>L</sub> =10pF, R <sub>L</sub> =50Ω		0.25		us
Select input to switch on time	T <sub>ON</sub>	C <sub>L</sub> =10pF, R <sub>L</sub> =50Ω		200		us
Select input to switch off time	T <sub>OFF</sub>	C <sub>L</sub> =10pF, R <sub>L</sub> =50Ω			100	ns
Break-Before-Make time	T <sub>BBM</sub>	Generated by design		100		ns
-3dB Bandwidth	BW	R <sub>L</sub> =50Ω, C <sub>L</sub> =2pF		1.2		GHz
Off isolation	OIRR	R <sub>L</sub> =50Ω, F=250MHz		-50		dB
Crosstalk	Xtalk	R <sub>L</sub> =50Ω, F=250MHz		-30		dB
Charge injection (Select input to common I/O)	Q <sub>g</sub>	C <sub>L</sub> =0.1nF, VCC=3.3V R <sub>G</sub> =0Ω, V <sub>G</sub> =GND		5		pC
Select pin input capacitance	C <sub>IN</sub>	VCC=0V		5		pF
D1n, D2n, Dn Off capacitance	C <sub>OFF</sub>	VCC=3.3V, $\overline{OE}$ =3.3V		5		pF
D1n, D2n, Dn On capacitance	C <sub>ON</sub>	VCC=3.3V, $\overline{OE}$ =0V		6.5		pF

Typical Characteristics (Ta=25°C, VCC=4.5V, unless otherwise noted)

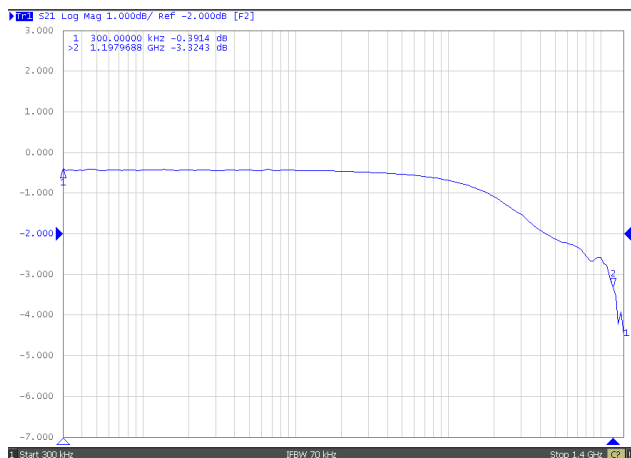

Bandwidth

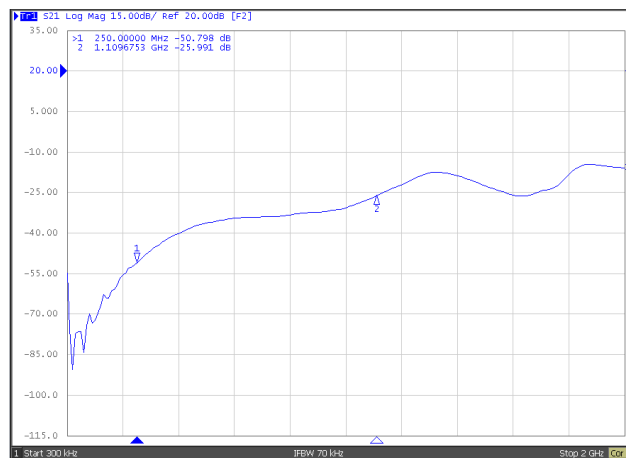

Off isolation



Crosstalk

Test Circuit

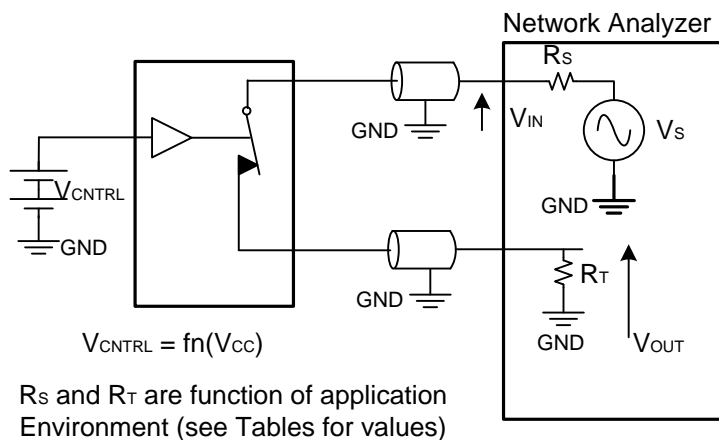

Figure 1. USB Bandwidth

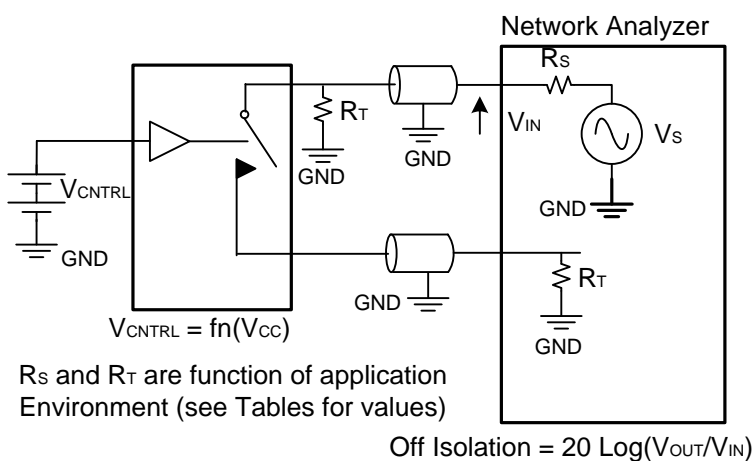

Figure 2. Channel Off Isolation

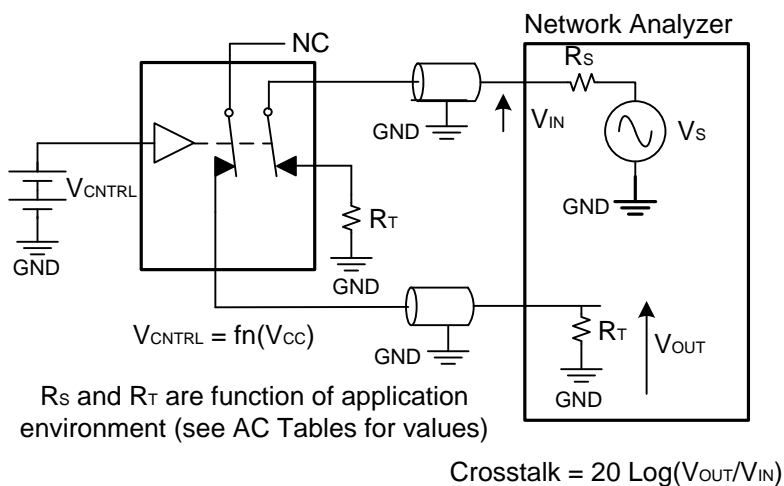
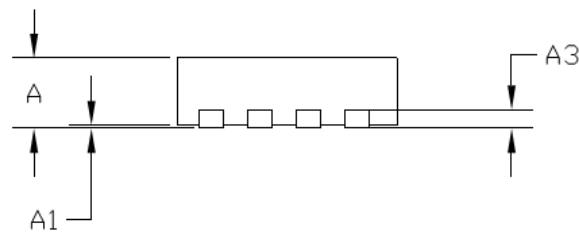
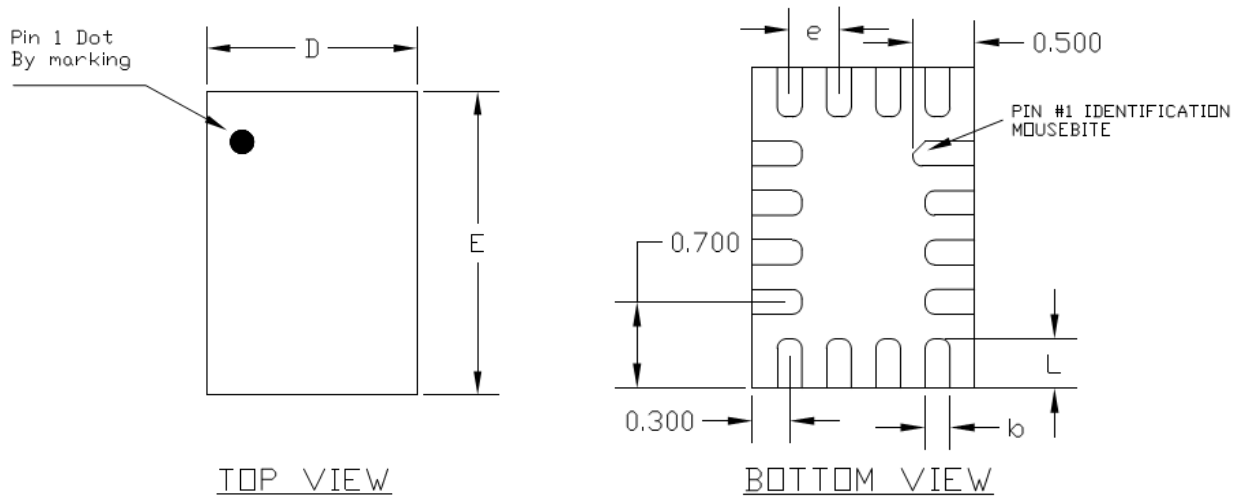

Figure 3. Non-Adjacent Channel-to-Channel Crosstalk

Package outline dimensions

QFN1826-16L



SIDE VIEW

Symbol	Dimension in Millimeters		
	Min.	Typ.	Max.
A	0.50	0.55	0.60
A1	0.00	-	0.05
A3	0.15 Typ.		
D	1.75	1.80	1.85
E	2.55	2.60	2.65
L	0.30	0.40	0.50
b	0.15	0.20	0.25
e	0.40 Typ.		